

Output from video unit See part 2

To page 2 of this document

**TACAN SIMULATOR Part 1: RF Circuits
Hoffman HL1 - 103D**

1-54. In the no signal condition, the plate voltage of V707B will drop to a point below 40 volts, the Zener level of CR704. As long as the circuit remains in this condition, there will be zero volts at the junction of C727 and CR704 and no deflection of meter M1101. During the presence of transmitter signal from the **equipment under test**, the grid of V707B is driven more negative as explained in paragraph 1-53. The increasing plate voltage of V707B overcomes the 40 volt Zener level of CR704. From this point, the anode voltage of CR704 will follow the plate voltage of V707B with a constant voltage differential of 40 volts. For example, if the plate voltage of V707B rises to 45 volts, the anode voltage of CR704 will rise to 5 volts. It is this differential voltage at the anode of CR704 that causes the meter to deflect up scale. Resistors R794 and R795 are meter multipliers which provide the proper current limitation through the meter. Diode, CR703, provides voltage limitation to protect the meter. The output of CR704 is also fed back to the cathode of peak power detector V901. The application of this negative feedback to the cathode of V901 limits the amplitude of the detected transmitter pulses and provides linear gain of the total amplifier. In this manner the output voltage of CR704, as measured by the peak power meter, will be directly proportional to the input at V901 times the gain of the total amplifier.

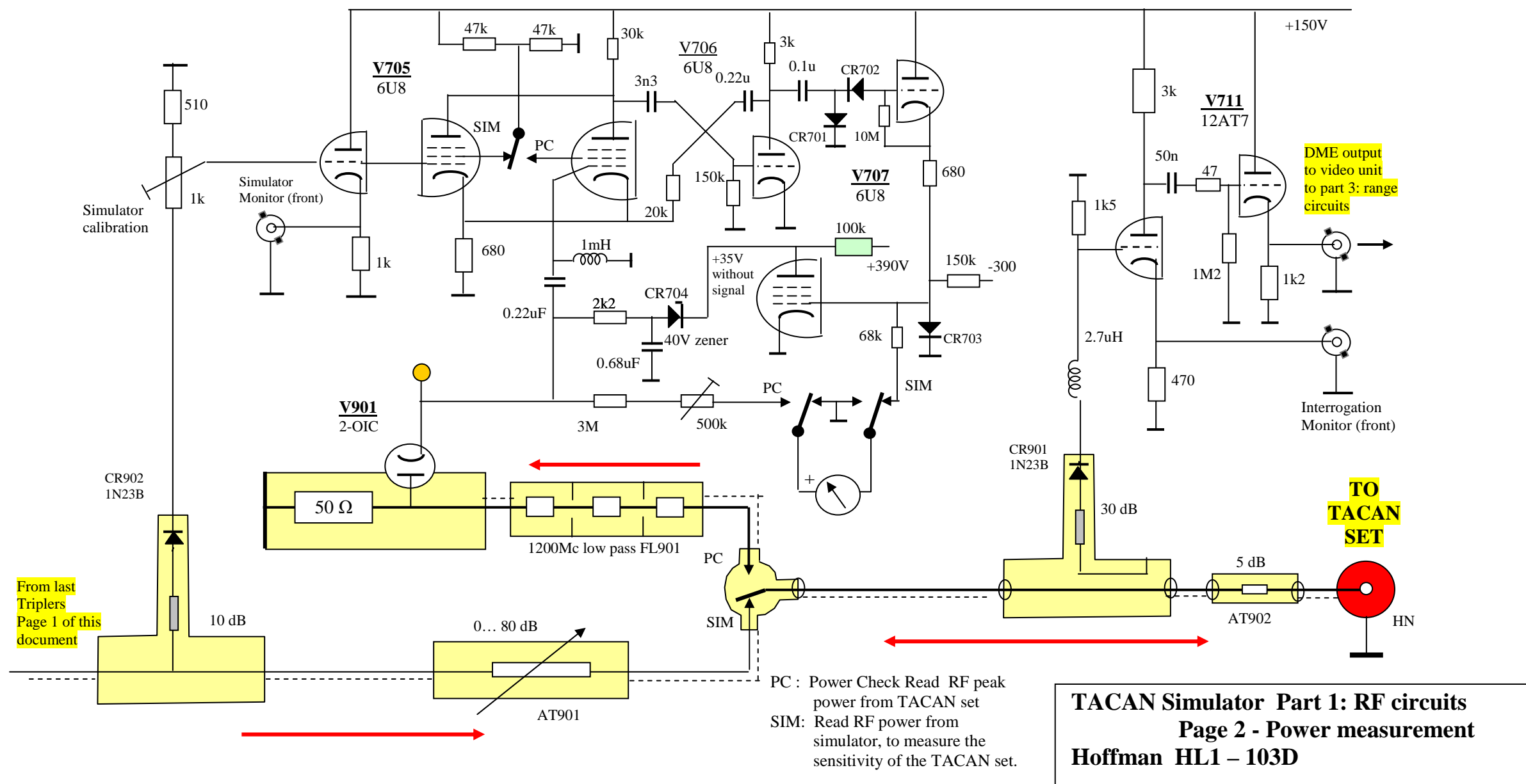

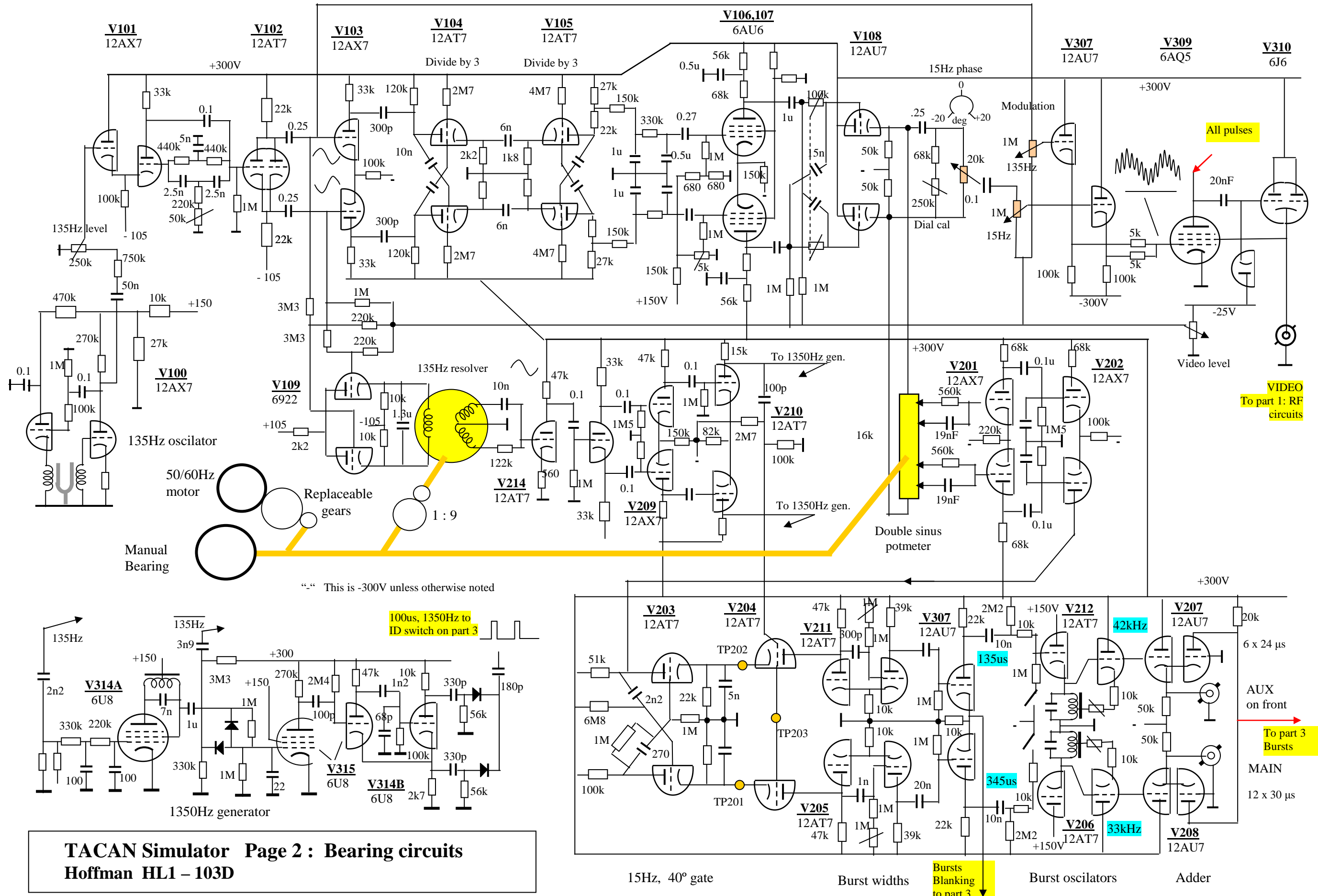

TACAN Simulator Page 2 : Bearing circuits
Hoffman HL1 - 103D

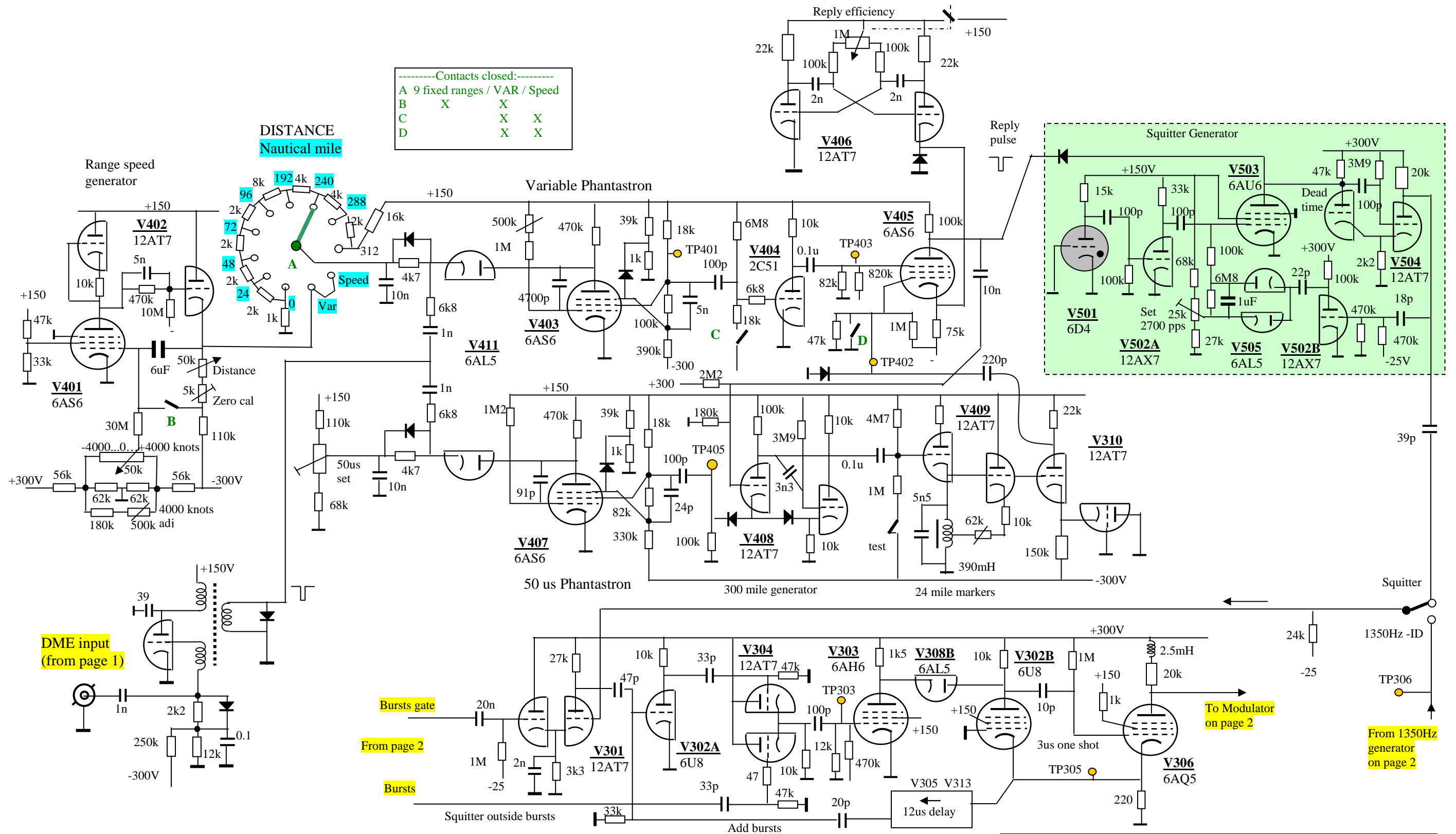

-----Contacts closed:-----

A	9 fixed ranges / VAR / Speed		
B	X	X	
C		X	X
D		X	X

DISTANCE
Nautical mile

DME input
(from page 1)

Bursts gate

From page 2

Bursts

To Modulator
on page 2

From 1350Hz
generator
on page 2

Tacan Simulator Part 3: Range circuits
Hoffman HL1 - 103D